

Wire-wound Chip Inductors - Open

ginvanix.com

GVLQ1812N Series

From 1.0 μH to 2200 μH

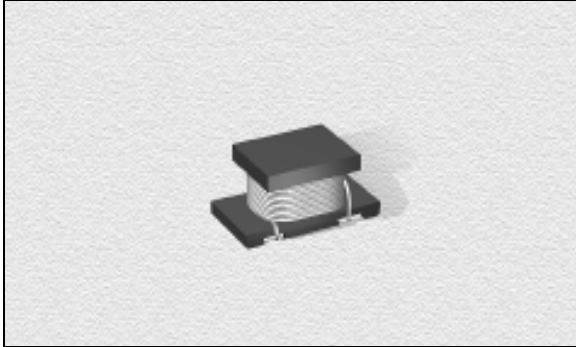

CHARACTERISTICS

- Description:** SMD power inductor
- Applications:** Power supplies for VTR, OA equipment, LCD televisions, PC notebooks, portable communication equipment, DC/DC converters, etc.
- Operating Temperature:** -25°C to +85°C
- Inductance Tolerance:** J = $\pm 5\%$, K = $\pm 10\%$ & M = $\pm 20\%$
- Packaging:** Tape & Reel
- Testing:** Tested on a HP4285A @ specified frequency
- Pads:** Soft copper and pre-tinned
- Additional Information:** Additional electrical & physical information available upon request
- Samples available. See website for ordering information.**

SPECIFICATIONS

Please specify tolerance code when ordering.
 GVLQ1812N-4R7_ ← J = $\pm 5\%$, K = $\pm 10\%$ M = $\pm 20\%$
 K or M ** J or K

Part Number	Inductance (μH)	Test Freq. (Hz)	Q Min.	DCR (Ω) Max.	SRF (MHz) Min.	Rated (mA) Max.
GVLQ1812N-1R0M	1.0	1M	20@1MHz	0.20	120	500
GVLQ1812N-1R2M	1.2	1M	20@1MHz	0.20	100	500
GVLQ1812N-1R5M	1.5	1M	20@1MHz	0.30	85	500
GVLQ1812N-1R8M	1.8	1M	20@1MHz	0.30	75	500
GVLQ1812N-2R2M	2.2	1M	20@1MHz	0.30	62	500
GVLQ1812N-2R7M	2.7	1M	20@1MHz	0.32	53	500
GVLQ1812N-3R3M	3.3	1M	20@1MHz	0.35	47	500
GVLQ1812N-3R9M	3.9	1M	20@1MHz	0.38	41	500
GVLQ1812N-4R7_*	4.7	1M	30@1MHz	0.40	38	500
GVLQ1812N-5R6_*	5.6	1M	30@1MHz	0.47	33	500
GVLQ1812N-6R8_*	6.8	1M	30@1MHz	0.50	31	450
GVLQ1812N-8R2_*	8.2	1M	30@1MHz	0.56	27	450
GVLQ1812N-100_**	10	1M	35@1MHz	0.56	23	400
GVLQ1812N-120_**	12	1M	35@1MHz	0.62	21	380
GVLQ1812N-150_**	15	1M	35@1MHz	0.73	19	360
GVLQ1812N-180_**	18	1M	35@1MHz	0.82	17	340
GVLQ1812N-220_**	22	1M	35@1MHz	0.94	15	320
GVLQ1812N-270_**	27	1M	35@1MHz	1.1	14	300
GVLQ1812N-330_**	33	1M	35@1MHz	1.2	12	270
GVLQ1812N-390_**	39	1M	35@1MHz	1.4	11	240
GVLQ1812N-470_**	47	1M	35@1MHz	1.5	10	220
GVLQ1812N-560_**	56	1M	35@1MHz	1.7	9.3	200
GVLQ1812N-680_**	68	1M	35@1MHz	1.9	8.4	180
GVLQ1812N-820_**	82	1M	35@1MHz	2.2	7.5	170
GVLQ1812N-101_**	100	1M	40@796kHz	2.5	6.8	160
GVLQ1812N-121_**	120	1M	40@796kHz	3.0	6.2	150
GVLQ1812N-151_**	150	1M	40@796kHz	3.7	5.5	130
GVLQ1812N-181_**	180	1M	40@796kHz	4.5	5.0	120
GVLQ1812N-221_**	220	1M	40@796kHz	5.4	4.5	110
GVLQ1812N-271_**	270	1M	40@796kHz	6.8	4.0	100
GVLQ1812N-331_**	330	1M	40@796kHz	8.2	3.6	95
GVLQ1812N-391_**	390	1M	40@796kHz	9.7	3.3	90
GVLQ1812N-471_**	470	1k	40@796kHz	11.8	3.0	80
GVLQ1812N-561_**	560	1k	40@796kHz	14.5	2.7	70
GVLQ1812N-681_**	680	1k	40@796kHz	17.0	2.5	65
GVLQ1812N-821_**	820	1k	40@796kHz	20.5	2.2	60
GVLQ1812N-102_**	1000	1k	40@252kHz	25.0	2.0	50
GVLQ1812N-122_**	1200	1k	40@252kHz	30.0	1.8	45
GVLQ1812N-152_**	1500	1k	40@252kHz	37.0	1.6	40
GVLQ1812N-182_**	1800	1k	40@252kHz	45.0	1.5	35
GVLQ1812N-222_**	2200	1k	40@252kHz	50.0	1.3	30

PHYSICAL DIMENSIONS

Size	A	B	C	D	E	F		G
						Min.	Min.	Min.
mm	4.5 \pm 0.3	2.6 \pm 0.2	3.6 \pm 0.2	3.2 \pm 0.2	3.2 \pm 0.2	1.0	1.0	1.0
inches	0.18 \pm 0.01	0.10 \pm 0.008	0.14 \pm 0.008	0.12 \pm 0.008	0.12 \pm 0.008	0.04	0.04	0.04

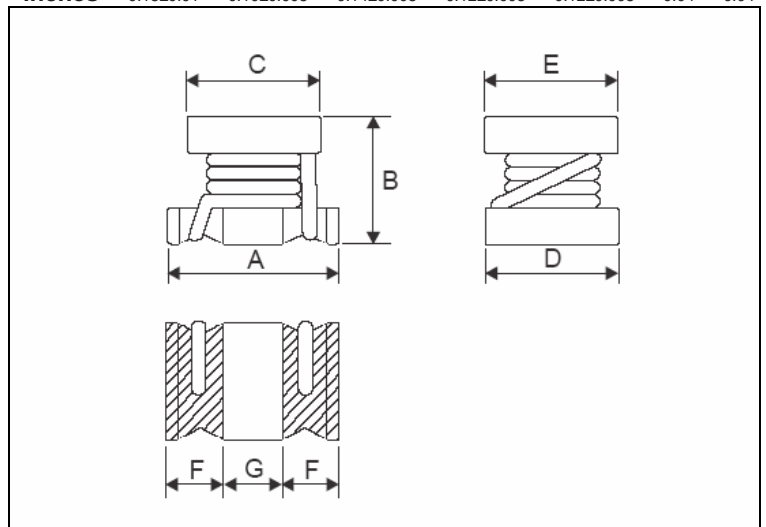

Ginvanix Electronics Corp.

180, Minsheng St., 303, Hukou, Hsinchu, Taiwan
 Tel: +886-3-5999899; Fax: +886-3-5901484; info@ginvanix.com